

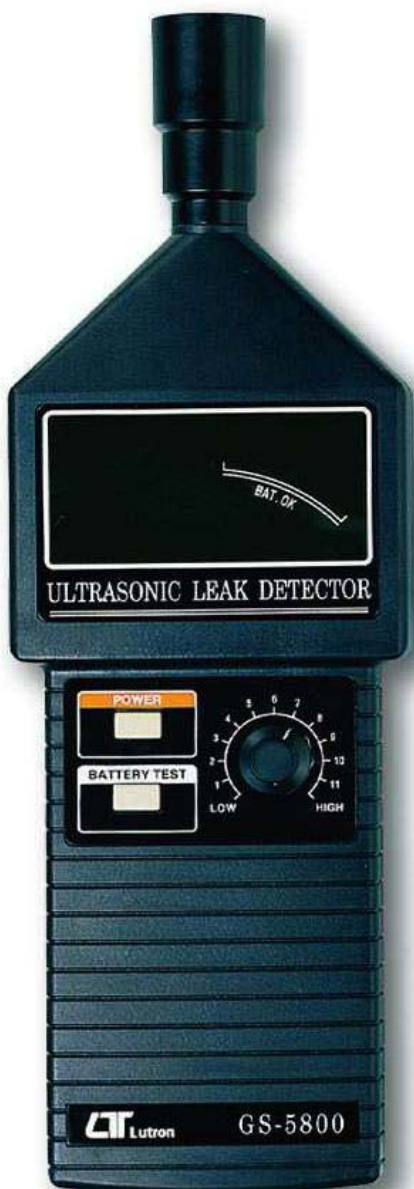

ULTRASONIC LEAKAGE DETECTOR ULTRASONIC TRANSMITTER

Model : GS-5800, GS-400

ISO-9001, CE, IEC1010



ULTRASONIC LEAKAGE DETECTOR

Model : GS-5800



ULTRASONIC TRANSMITTER

Model : GS-400



LUTRON ELECTRONIC



The Art of Measurement

ULTRASONIC LEAKAGE DETECTOR

Model : GS-5800

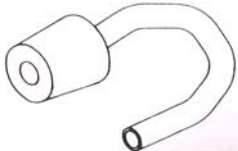
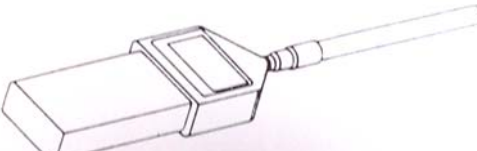
FEATURES	
ULTRASONIC LEAKAGE DETECTOR is designed to locate the source of the ultrasonic emissions generated by gas, air leaks.... The leakage level is displayed by "Bar LED Display Panel" and converted to audible sound by either internal buzzer or external optional earphone.	
SPECIFICATIONS	
Sensitivity for Leakage Indicator	Bar LED display panel & audible tone. * <i>The LED display indicator of the detector is a relative measurement only.</i>
Frequency Response	20 KHz to 100 KHz.
Power Supply	DC 9V battery. 006P, MN1604 (PP3) or equivalent, Alkaline or heavy duty type battery.
Power Consumption	Approx. DC 34 mA.
Operating Temp.	0 °C to 50 °C (32 °F to 122 °F).
Operating Humidity	Less than 80% RH.
Weight	Approx. 260 g/0.57 LB (including battery).
Size	HWD 255 x 70 x 28 mm (10.0 x 2.8 x 1.1 inch).
Accessories Included	Operational manual.....1 PC. Rubber bottle plug with plastic tubing.....1 PC. 1/2 inch PVC pipe.....1 PC. Hard carrying case.....1 PC.
Optional Accessory	Earphone, Model : EA-100
MISCELLANEOUS ACCESSORIES (accessories included)	
Rubble bottle plug with plastic tubing	1/2 inch PVC pipe
	

ULTRASONIC TRANSMITTER

Model : GS-400

SPECIFICATIONS	
Frequency Output	40 KHz.
Oscillator Circuit	640 KHz crystal time base & divided by 16.
Operating Temperature	0 °C to 50 °C (32 °F to 122 °F).
Operating Humidity	Less than 80% RH.
Power Supply	DC 9V battery. 006P, MN1604 (PP3) or equivalent, Alkaline or heavy duty type battery.
Power Consumption	Approx. DC 7.5 mA.
Weight	122 g/0.27 LB (included battery).
Size	146 x 50 x 26 mm (5.7 x 2.0 x 1.0 inch).
Accessories Included	Operational manual.....1 PC.

Applications for Ultrasonic transmitter (GS-400) cooperate with the Ultrasonic Leakage Detector (GS-5800)

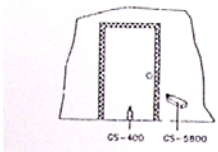
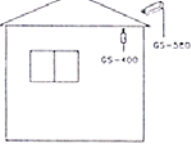
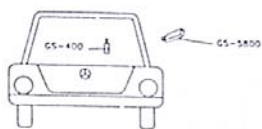
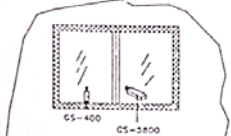
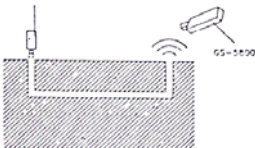
<i>Air leaks around door seals</i> 	<i>Water leaks in roofs</i> 	<i>Windshield leaks</i> 
<i>Air leaks around window seals</i> 	<i>Conduit & pipe identification</i> 	<i>Others (GS-5800 only) :</i> * Vacuum leaks. * Gas or air leaks. * Leaks in refrigeration and air condition systems. * Tire & tube leaks. * Engine seals.